



Hardware Product Innovation of the Year



Sygnof-i Wireless Optical Detector (SYG-PA)

The SYG-PA Sygnof-i Optical Detector is the latest in wireless smoke detector technology.

The detector utilises dual optical smoke detection technologies and algorithms for improved performance, maintaining the highest levels of false alarm rejection.

Utilising well-proven adaptive radio signal processing algorithms it ensures the highest levels of life safety and system reliability are achieved.

In-built magnet test allows easy activation to verify correct functionality and response.

TECHNICAL DATA

Operating frequency range	868 – 870 MHz
Max radiated power	14dBm (25mW)
Dimensions	110mm x 70mm
Weight (without batteries)	155g
Batteries	2x CR123A
Operating Temperature	-10°C to +55°C
Max humidity (non condensing)	95% RH
IP Rating	40

KEY FEATURES

- Advanced dual optical chamber design
- Dual angle scattering analysis
- Advanced drift compensation
- Bi-directional wireless communication
- Can be used with Sygnof-i addressable and conventional translators
- 22 pairs of field channels
- Dual channel redundancy
- Long communication range (\cong 1 km in open air)
- 10 year battery life
- Utilises standard low-cost lithium battery technology
- Device identification tab
- Fast test feature for engineer testing
- Easy scan & link programming option
- Security screw to prevent tampering and unwanted removal
- 3rd party approved
- 5 year product warranty
- Tri-coloured LED

TECHNICAL INFORMATION

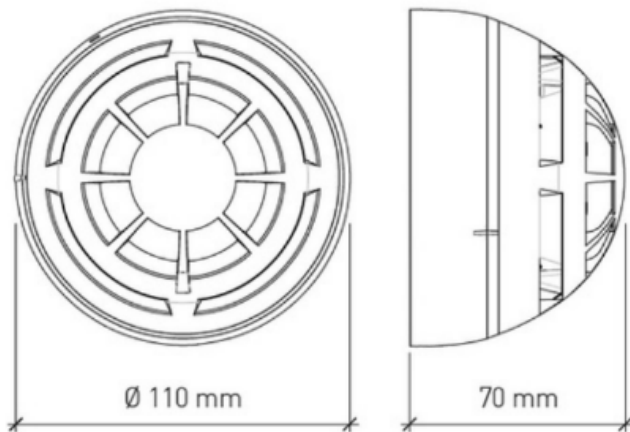

APPROVALS

- BS EN54-7 Smoke Detectors
- BS EN54-25: Components using radio links

BASE COMPATIBILITY

This device is supplied with a standard base and is incompatible with the following sounder bases:
SYG-BS | SYG-BSB-23W | SYG-BSB-23R

