

Sygnof Wireless Output Module

GENERAL DESCRIPTION

The **SYG-OM** is a device that acts an interface between the Sygno-fi wireless security system and any external device that works on a "switch on / switch off" criteria. As an example, it can provide activation power supply for conventional sounders or voltage-free relay contact switching capability for self-powered devices.

SYG-OM is battery powered and doesn't need any external power supply.

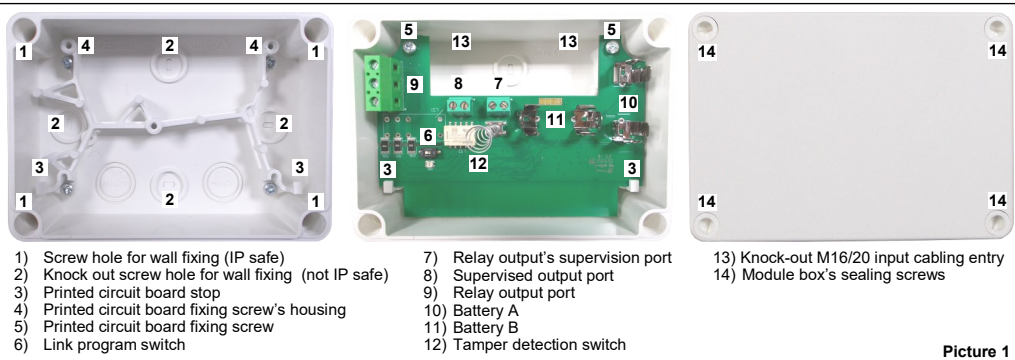

Picture 1

DEPLOYMENT PROCEDURE

- | | |
|---|--|
| <ol style="list-style-type: none"> 1) Select a location for the module.
See LOCATION SELECTION. 2) Unbox the module from its packaging. 3) Detach the top cover.
See HANDLING THE TOP COVER. 4) Uninstall the printed circuit board from the box.
See HANDLING THE PRINTED CIRCUIT BOARD. 5) Knock-out the required M16/20 input cabling entries.
See CABLE ENTRY. 6) Fix the module's box to the wall.
See WALL INSTALLATION. | <ol style="list-style-type: none"> 7) Power up the module.
See POWERING UP - FIRST TIME USE.
See POWERING UP - RECOVERY. 8) Link the module to the system.
See LINKING - WAKE-UP.
See LINKING - ONE-BY-ONE. 9) Reinstall the printed circuit board.
See HANDLING THE PRINTED CIRCUIT BOARD. 10) Wire up the required output cabling to the module.
See WIRING. 11) Seal the module with its top cover.
See HANDLING THE TOP COVER. 12) Test the module.
See TESTING. |
|---|--|



WARNINGS AND LIMITATIONS

Our devices use high quality electronic components and plastic materials that are highly resistant to environmental deterioration. However, after 10 years of continuous operation, it is advisable to replace the devices in order to minimize the risk of reduced performance caused by external factors. Ensure that this device is only used with compatible control panels. Detection systems must be checked, serviced and maintained on a regular basis to confirm correct operation. Smoke sensors may respond differently to various kinds of smoke particles, thus application advice should be sought for special risks. Sensors cannot respond correctly if barriers exist between them and the fire location and may be affected by special environmental conditions. Refer to and follow national codes of practice and other internationally recognized fire engineering standards. Appropriate risk assessment should be carried out initially to determine correct design criteria and updated periodically.

Use only in Sygno-fi fire detection and alarm systems.

WARRANTY

All devices are supplied with the benefit of a limited 3 years warranty relating to faulty materials or manufacturing defects, effective from the production date indicated on each product. This warranty is invalidated by mechanical or electrical damage caused in the field by incorrect handling or usage. Product must be returned via your authorized supplier for repair or replacement together with full information on any problem identified. Full details on our warranty and product's returns policy can be obtained upon request.

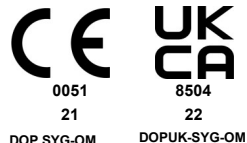

Eurotech Fire Systems Ltd
19/20 Stratfield Park
Elettra Avenue
Waterlooville
Hampshire
PO7 7XN
United Kingdom

SYG-OM
EN 54-25:2008
EN 54-18:2005

LOCATION SELECTION

Select a location for the module that conforms to your local applicable safety standards and that is in a good position for sending / receiving wireless signals to / from the father **SYG-W2W**, **SYG-CEM** or **SYG-EM** network device.

Mount the module as far as possible from metal objects, metal doors, metal window openings, etc. as well as cable conductors, cables (especially from computers), otherwise the operating distance may greatly drop.

The **SYG-OM** must NOT be installed near electronic devices and computer equipment that can interfere with its wireless communication quality.



It is advisable to use the SYG-STK survey kit to locate a good wireless installation location.

HANDLING THE TOP COVER

To uninstall the top cover unscrew the four module box's sealing screws and detach the cover. To install it perform the opposite operation; take care to seal the module in order to maintain its IP rating.

HANDLING THE PRINTED CIRCUIT BOARD

To uninstall the printed circuit board, remove first the two blocking fixing screws, then carefully extract the board from its box. To reinstall it, insert its lower side under the two plastic stops, then install the two blocking screws.



Electrostatic sensitive device: observe precautions when handling the printed circuit board and making connections.

CABLE ENTRY

The module's box is designed with six M16/20 cable entry knockout holes, distributed on the lateral sides; the two entries above the supervised output and relay supervision ports give the best choice. These entries allow sealed, gland fitted output port cables to be connected to the device and, at the same time, to preserve the original IP protection rating. Fit the cable's gland (or glands) into the "knocked out" device box's cable entries.



To avoid damage, remove the printed circuit board before knocking out the cable entry holes.

WALL INSTALLATION

Knockout wall fixing screw openings are indicated in picture 1; these openings, once knocked out, compromise the IP rating of the module's box. Alternatively, you can choose to use the four IP safe screw holes (picture 1).

WIRING

The output line has to be connected either to the supervised output port (Picture 2) or to the relay port (Picture 3) of the output module. Use the supervision port to add open and short circuit system's surveillance over the relay port.

Make sure to install the R_{EOL} resistor at the end of the supervised output line; if line supervision is not desired, fit the R_{EOL} directly across the supervised output dipole at the beginning of the line.



Ports are polarity sensitive.

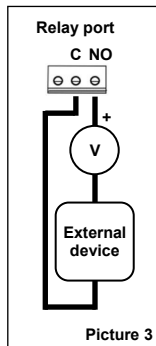
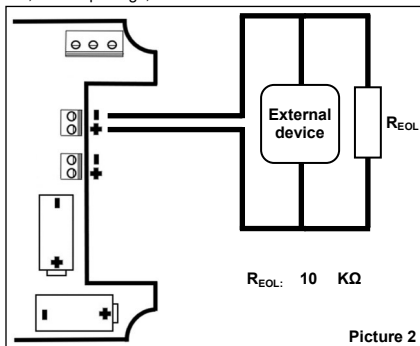

BATTERY FAULTS AND BATTERY SUBSTITUTION PROCEDURE

When one or both batteries are low in charge, a specific fault message is routed to the control panel. If such event occurs:

- 1) Remove the top cover.
- 2) Extract both batteries.
- 3) Insert both new batteries into their holders, correctly oriented.
See **POWERING UP - DEVICE LINKED TO THE SYSTEM**.
- 4) Reinstall the top cover.



Always install the R_{EOL} on the supervised output and relay supervision ports, even if they are not used.

TESTING

Test the module as follows:

- 1) Activate the alarm condition.
- 2) Check the correct activation of the device on the output line.
- 3) Remove the alarm condition.



When a low battery condition is indicated, both batteries must be changed altogether.

Batteries must be brand new. Do not touch the Link / program switch. Ensure that the batteries are installed properly, with their correct polarities.



Local safety standards may require you to test these devices on a regular basis.

LED INDICATOR STATUS MESSAGES

The LED indicator's messages are used only during installation and servicing. LED indicator is inactive when the front cover is in place for saving up battery charge (and due to the fact that normally the LED is hidden by the front cover).

Device status	LEDs indication
Power up (DIP on "ON")	Blinks red 4 times
Power up (DIP opposite "ON")	Blinks green 4 times
Entering wake-up mode	Blinks alternatively green / red 4 times
Link success (one-by-one)	Blinks green 4 times, then the same pattern again
Link failure (one-by-one)	Enters wake-up mode and signals "Entering wake-up mode" following this failure
Link success (wake-up)	Blinks green 4 times, then same pattern again
Link failure (wake-up)	Blinks green 4 times, then blinks red on once, then blinks alternatively green / red 4 times
Normal condition	LED off (can be programmed so as to blink green every wireless communication)
Alarm activation	Blinks red every 2 seconds
Battery fault	LED off (can be programmed so as to blink amber every 5 seconds)
Tamper fault	LED off
Replaced	Blinks amber 2 times
Supervised output / supervision port fault	LED off (can be programmed so as to blink amber every 5 seconds)

Table 1



With the front cover installed, the LED indicator remains inactive.

POWERING UP AND LINKING - PRELIMINARY NOTES

SYG-OM needs to be powered up with the supplied batteries. Linking is the operation through which **SYG-OM** is "wirelessly connected" to a **SYG-W2W**, **SYG-CEM** or **SYG-EM** Sygno-fi network device.

POWERING UP - FIRST TIME USE

Use this procedure the first time you power up a **SYG-OM**.

- 1) Make sure the Link / program switch is set on "ON".
- 2) Insert the two supplied batteries into their device's lodgments.

POWERING UP - DEVICE LINKED TO THE SYSTEM

Use this procedure when a **SYG-OM** is successfully linked to its Sygno-fi system and you have to extract one or both batteries (e.g. batteries substitution).

- 1) Reinsert the battery or both batteries into their lodgments.

If performing a batteries substitution, use two brand new batteries and substitute both of them. Do not touch the Link / program switch.

POWERING UP - RECOVERY

Use this procedure when you fail to link successfully a **SYG-OM** or you want to link it again.

- 1) Move alternatively the Link / program switch 5 times.
- 2) Set the Link / program switch on "ON".
- 3) Insert the two supplied batteries into their device's lodgments.

LINKING - WAKE-UP

"Wake-up" linking consists in associating one or more child devices to the Sygno-fi system altogether in a single operation.

Wake-up is performed either through the **SygNEX** software or the **SYG-W2W / SYG-CEM** keyboard-screen interface; it CANNOT be done through **SYG-EM** devices.

- 1) Create the "virtual model" of the **SYG-OM** either on **SygNEX** or on the **SYG-W2W / SYG-CEM**.
- 2) Power-up the module (either "first time use" or "recovery").
- 3) Set the Link / program switch **OPPOSITE** to "ON".
- 4) Trigger the wake-up procedure either from **SygNEX** or from the **SYG-W2W / SYG-CEM**.
- 5) Wait the end of the "wake-up" linking procedure.
- 6) Check on **SygNEX** or from **SYG-W2W / SYG-CEM** for linking success. Consult their user manual.

LINKING - ONE-BY-ONE

"One-by-one" linking consists in associating one child device at a time to the Sygno-fi system.

This operation is performed either through the **SygNEX** software or the **SYG-W2W / SYG-CEM** keyboard-screen interface; it CANNOT be done through **SYG-EM** devices.

- 1) Create the "virtual model" of the child device either on **SygNEX** or on the **SYG-W2W / SYG-CEM**.
- 2) Trigger the linking procedure either from **SygNEX** or from the **SYG-W2W / SYG-CEM**.
- 3) Power-up the child device (either "first time use" or "recovery").
- 4) Set the child device's Link / program switch **OPPOSITE** to "ON".
- 5) Wait the end of the "one-by-one" linking procedure.
- 6) Check on **SygNEX** or from **SYG-W2W / SYG-CEM** for linking success. Consult their user manual.



Always ensure that the batteries are installed properly, with their polarities matching the indications on picture 2 or on the device.

TECHNICAL SPECIFICATIONS *

Specification	Value
Communication range with SYG-W2W , SYG-CEM or SYG-EM network devices	200 m (in open space)
Wireless frequency band	868 MHz
Number of wireless channels	66
Radiated power	14 dBm (25 mW)
Operating temperature range	-10 °C to 55 °C
Maximum humidity (non condensing)	95% RH
Certified IP rating (EN 54)	IP 30
Design IP rating (not EN 54 certified)	IP 65
Knockout cable entry specification	M16/20
Wire gauge range compatible with the terminal blocks of the supervised output port and relay supervision port	From 0.5 mm ² to 2.5 mm ²
Wire gauge range compatible with the relay port's terminal blocks	From 0.5 mm ² to 4.0 mm ²

* See TDS-TWMOS technical specification document for further technical data.

Table 2**BATTERY SPECIFICATIONS**

Specification	Value
Batteries type	CR123A (3 V, 1.25 Ah)
Batteries lifespan *	4 years
Low battery threshold value (nominal)	2.850 V

* Batteries lifespan depends by environmental conditions, default monitor settings and link quality.

Table 3**PORTS SPECIFICATIONS**

	Voltage setting	Maximum allowed current load
Supervised output port	12 V	100 mA (at 25 °C)
	24 V	50 mA (at 25 °C)

Table 4

	End of Line impedance limits				Module status	Notes
	Min	Typ	Max	Units		
Supervised output port	6.5	10	14	kΩ	Normal	
	0	-	2.4	kΩ	Fault	Short Circuit
	14.2	-	+∞	kΩ	Fault	Open Circuit
	R_{EOL}	8	10	12	kΩ	

Table 5

	End of Line impedance limits				Module status	Notes
	Min	Typ	Max	Units		
Relay supervision port	6.5	10	14	kΩ	Normal	
	0	-	2.4	kΩ	Fault	Short Circuit
	14.2	-	+∞	kΩ	Fault	Open Circuit
R_{EOL}	8	10	12	kΩ		

Table 6

	Maximum allowed voltage	Maximum allowed current load
Relay output port	30 V	2 A

Table 7