

# EUW-RI-01

## STATIC WIRELESS REMOTE INDICATOR

### GENERAL DESCRIPTION

The wireless remote indicator is an output device which, activated by the control panel, switches on its red light in the event of an emergency fire alarm. The activation command is sent from the control panel to the indicator through the wire to wireless translator interface module and other possible wireless expander modules.

### GENERAL OVERVIEW



Picture 1

**PRIMARY BATTERY  
LODGEMENT**

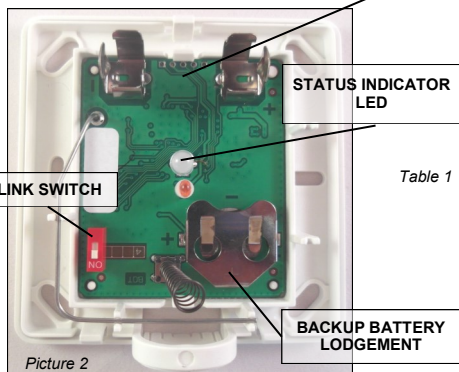

**LINK SWITCH**

**STATUS INDICATOR  
LED**

**BACKUP BATTERY  
LODGEMENT**

Table 1

### TECHNICAL SPECIFICATIONS \*\*\*\*

Operating frequency range	868.15 MHz - 869.85 MHz
Max radiated power	5 dBm (3 mW)
Radio signal's modulation type	FSK
Operating frequency channels	7
Communication range with the translator or the expander *	200 m (in open space)
Main battery type	CR123A (3 V & 1.2 Ah)
Backup battery type	CR2032A (3 V & 235 mAh)
Main battery lifespan **	5 years ***
Backup battery lifespan **	2 months ***
Operating temperature	from -10 to +55 °C
Max tolerated humidity (no condensing)	95% RH
IP rating	42
Dimensions	80 mm x 80 mm x 27 mm
Light's signal pattern	Continuous
Compatible Wirelex program version	up to release 5.1.3
Compatible translator model	VW2W100
Period of control signals transmission	7 seconds suggested
Supervision period	3 minutes suggested

\* Ideal operating range: may vary consistently according to environmental conditions.

\*\* When a low battery condition is indicated, both, main and secondary, batteries must be changed altogether.

\*\*\* These lifespan values refer to the device being programmed with a control signals transmission period of 32 seconds.

\*\*\*\* Check latest version of document TDS-SGF1200-X for further data, obtainable from your supplier.

### STATUS INDICATOR LED

The wireless remote indicator's PCB (picture 2) is equipped with a bicolour LED (red/green) that provides visual indication for functional conditions and battery levels as indicated in table 2.

Device's status	Green LED	Red LED
Power up	1 second green, then 0.5 second red for 4 times	
Programming and linking to the system	Blinking until linking and programming is completed	
Normal condition	-	-
Main battery fault	-	0.5 second on and 10 seconds off
Backup battery fault	0.5 second on and 10 seconds off	-
Both batteries fault	-	0.5 second on and 10 seconds off
Lost link with translator / expander	0.5 second green and red (amber) and 1 second off	

Table 2

### DEVICE'S POWER SUPPLY AND LINKING

The remote indicator device becomes part of the wireless system after only after it is linked to a parent translator or a parent expander. It is possible to perform the linking in two ways:

- From the translator module interface: it can be done if the system hasn't got any expanders; nevertheless the suggested "Period of control signals transmission" and "Supervision period" (TECHNICAL SPECIFICATIONS table) cannot be applied.
- Through the "Wirelex Fire" software: if the system has one or more expanders; suggested "Period of control signals transmission" and "Supervision period" (TECHNICAL SPECIFICATIONS table) parameters can be applied.

**EITHER WAY IS LINKED, THIS REMOTE INDICATOR MODEL MUST BE LINKED AS A BATTERY POWERED OUTPUT MODULE.**

The following procedure does not change whether is made through the translator or the Wirelex.

1) Move the link switch to position "ON".

2) Insert the backup battery into its housing (picture 3).

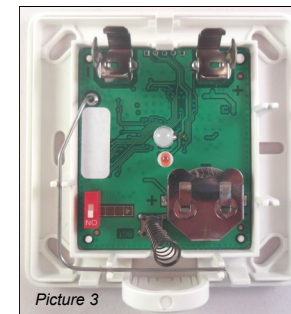

Picture 3

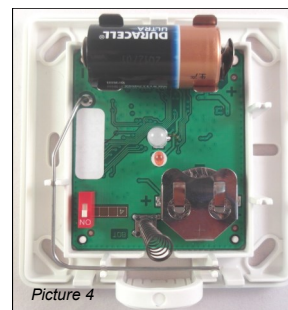

Picture 4

3) Insert the primary battery into its housing; the visual LED indicator switches on accordingly (check "Power up" in table 2).

**Ensure that both battery's polarities are correct!!!**

### WARNINGS AND LIMITATIONS

Our devices use high quality electronic components and plastic materials that are highly resistant to environmental deterioration. However, after 10 years of continuous operation, it is advisable to replace the devices in order to minimize the risk of reduced performance caused by external factors. Ensure that this device is only used with compatible control panels. Detection systems must be checked, serviced and maintained on a regular basis to confirm correct operation. Smoke sensors may respond differently to various kinds of smoke particles, thus application advice should be sought for special risks. Sensors cannot respond correctly if barriers exist between them and the fire location and may be affected by special environmental conditions.

Refer to and follow national codes of practice and other internationally recognized fire engineering standards. Appropriate risk assessment should be carried out initially to determine correct design criteria and updated periodically.

### WARRANTY

All devices are supplied with the benefit of a limited 3 year warranty relating to faulty materials or manufacturing defects, effective from the production date indicated on each product. This warranty is invalidated by mechanical or electrical damage caused in the field by incorrect handling or usage.

Product must be returned via your authorized supplier for repair or replacement together with full information on any problem identified. Full details on our warranty and product's returns policy can be obtained upon request.

**CE0051 UK**  
**CE0889 CA**

Eurotech Fire Systems Ltd 19/20 Stratfield Park, Eletra Avenue Waterlooville, Hampshire PO7 7XN United Kingdom

R&TTE declaration of conformity can be acquired directly from Argus Security or from [www.argussecurity.it](http://www.argussecurity.it)

Designed for EN 54-25:2008 Components using radio links

EUW-RI-01

For use in compatible fire detection and alarm system

4) When the translator / expander is looking for a new device for linking, move the link switch to position "1" in order to initiate communication with the translator / expander module; the visual LED indicator switches on accordingly (see "Programming and linking to the system" in table 2).

**IMPORTANT NOTE!**

Programming is considered to be completed successfully only if there is an indication of programming success either by the translator or the Wirelex software.

*If the linking and programming operation fails, check if mistakes were made with the translator or the Wirelex, remove the batteries, switch alternatively the "ON / 1" switch a few times in order to discharge the internal capacitor and then start again from point 1) re-performing the linking procedure.*

**COMMUNICATION QUALITY ASSESSMENT**

It is possible to assess the wireless communication quality between the wireless remote indicator and the translator / expander by using a testing feature built in the device.

After a successful linking operation, by positioning the link switch on the "ON" position, the device's LED will start blinking according to table 3.

**Always remember to reposition the switch to "1" after the assessment operation: device will NOT work operatively while the switch is set on the "ON" position.**

Communication quality	Assessment	Device's indication
No connection	Fail	Two red blinks
Link margin is less than 10 dB	Poor	One red blink
Robust communication with link margin from 10 dB to 20 dB	Good	One green blink
Robust communication with link margin over 20 dB	Excellent	Two green blinks

Table 3

**HOW TO REMOVE AND REINSTALL THE FRONT COVER**

Remote indicator's installation requires the device's top cover to be removed from the its bottom; position the tip of a small screwdriver in the slot portrayed in picture 5, then lever off the cover GENTLY and CAREFULLY.

Reinstalling the cover consists in performing the operation portrayed in picture 6.

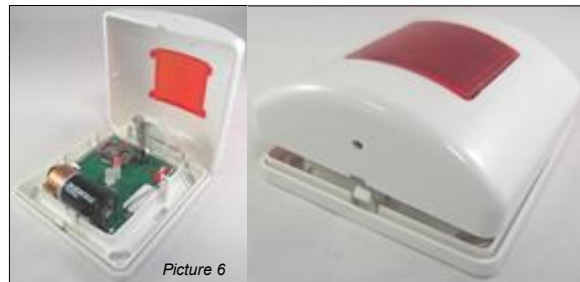

**DEVICE'S PLACEMENT**

For specific information regarding detector and device's spacing, placement and special applications refer to your specific national standards.

*It is strongly advised to mount the device as far as possible from metal objects, metal doors, metal window openings, etc. as well as cable conductors, cables (especially from computers), otherwise the operating distance may greatly drop. The device should not be installed near electronic devices and computer equipment that can interfere with the reception's quality.*

- 1) Select the position of the remote indicator before installing and fixing it. **Verify, from that position, that the communication between the device and the translator / expander is correctly established and working (see the COMMUNICATION QUALITY ASSESSMENT paragraph).**
- 2) Install and fix the device's rear cover in the selected position using the screws provided in the product's packaging (picture 7).
- 3) Install the front cover onto the wall-fixed rear cover: see the HOW TO REMOVE AND REINSTALL THE FRONT COVER paragraph.

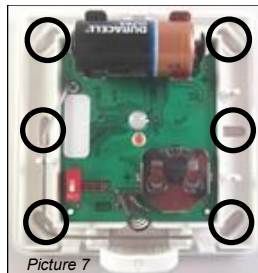

**BATTERY FAULTS**

If a battery fault condition is detected on the wireless remote indicator, a low battery fault message is sent to the control panel and notified to the user by the panel itself. This condition is locally signaled by the module's status indicator LED (check table 2).

**WHEN A LOW BATTERY CONDITION IS INDICATED, BOTH, MAIN AND SECONDARY, BATTERIES MUST BE CHANGED ALTOGETHER.**

**TAMPER DETECTION FEATURE**

The opening of the wireless remote indicator's case is signaled by the control panel as a tampering attempt; the device's PCB is equipped with a spring-tactile switch assembly: if the case is closed this spring is kept pressed, but when released (and this occurs if the case is opened) the remote indicator sends a tamper attempt message to the control panel which provides the signalization of such event.

The signalization of this event is automatically revoked a short time after the case is properly closed again.

**TESTING**

In order to test the functionality of the installed wireless indicator proceed as follows: activate an alarm condition on the control panel (by a call-point or sensor in the installed system): the control panel will lit the alarm indicator.

After each test the device must be reset from the control panel (see the RESET paragraph).

If the test fails check whether the batteries are charged, if mistakes were done previously or even if the system is activated. If the remote indicator's functionality is hopeless, send back the device to your distributor for repair or substitution.

**All devices must be tested after installation and, successively, on a periodic basis.**

**RESET**

To reset the wireless remote indicator from alarm it is necessary to reset the system from the control panel: alarm indication will deactivate.

**MAINTENANCE**

- 1) Before starting any maintenance work (e.g. batteries substitution), disable the system.
- 2) Remove the front cover from the device's box.
- 3) Perform the planned necessary maintenance operations.
- 4) After the device has been serviced, reinstall correctly the front cover, reactivate the system and check correct operation as described under the TESTING paragraph.